



# TRANSFER POINT PRODUCTS

CONTAIN • CONTROL • ADVANCE

L3649





# PROBLEM

## FUGITIVE MATERIALS

Escape of materials from conveyors is an everyday occurrence. It occurs in the forms of spillage and leakage from transfer points or carryback that adheres to the belt past the discharge point and drops off along the conveyor return. It also occurs in the form of airborne dust that is carried off and settles on structures, equipment and the ground.

Carryback falls under the conveyor, spillage falls to the sides and dust falls on everything, including systems and structures above the conveyor. Left unchecked, fugitive materials represent an ever-increasing drain on a conveyor's efficiency, productivity and profitability. Materials lost from the conveyor system cost the plant in a number of ways.

- Reduced operating efficiency
- Increased conveyor maintenance costs
- Reduced plant safety
- Lowered employee morale
- Diminished product quality
- Heightened scrutiny from outside agencies





# SOLVED

## THE MARTIN® SOLUTION

Through proper design and maintenance, bulk material handling operations can run cleanly, safely and efficiently.

By preventing spillage and airborne dust, Martin Engineering's Transfer Point Products can help reduce equipment damage, reduce cleanup, control maintenance expenses and improve the overall plant safety.

Martin Engineering is more than an equipment supplier. We are problem solvers dedicated to improving transfer point performance.

**Problem Solved™**  
**GUARANTEED!**



# A NEW STANDARD FOR CONVEYOR DESIGN

Martin Engineering has created a new standard in conveyor architecture. The EVO® System rethinks the problems of traditional conveyor design from the ground up and places more emphasis on safety, control of fugitive material and ease of service.

Designed to provide a clean, safe and productive system, the EVO® Conveyor Architecture is cost competitive and flexible enough to be easily upgradeable to solve operation-specific problems. The EVO® products can be used in part or as a whole system; in conjunction with or as a complement to traditional C-Channel conveyor structure and offers a number of benefits over conventional conveyor design.

- Reduce Dust and Spillage
- Improve Safety
- Reduce Cleanup Headaches
- Improve Regulatory Compliance
- Improve Serviceability
- Simple Accessibility
- Upgradeable and Cost-Efficient



# KEY COMPONENTS

## (1) BELT SUPPORT

For an effective, minimum-spillage transfer point, it is essential that the belt's line of travel be stabilized with proper belt support in the load zone.

## (2) SEALING SYSTEM

A crucial requirement in any transfer point designed for reduced spillage and high efficiency is an effective sealing system at the edge of the belt.

## (3) BELT TRACKING

Belt tracking must be controlled before spillage can be eliminated.

## (4) TAIL PULLEY PROTECTION

Pulley protection plows are installed to remove lumps and stray components from the belt before they can damage the pulley or belt.

## (5) CHUTE STRUCTURE

Bulk materials should flow through a transfer chute evenly and consistently.

## (6) DUST MANAGEMENT

Airborne dust is a common problem in bulk-materials handling operations. When both material spillage and airborne dust are controlled, the operation will be cleaner, safer and more productive.

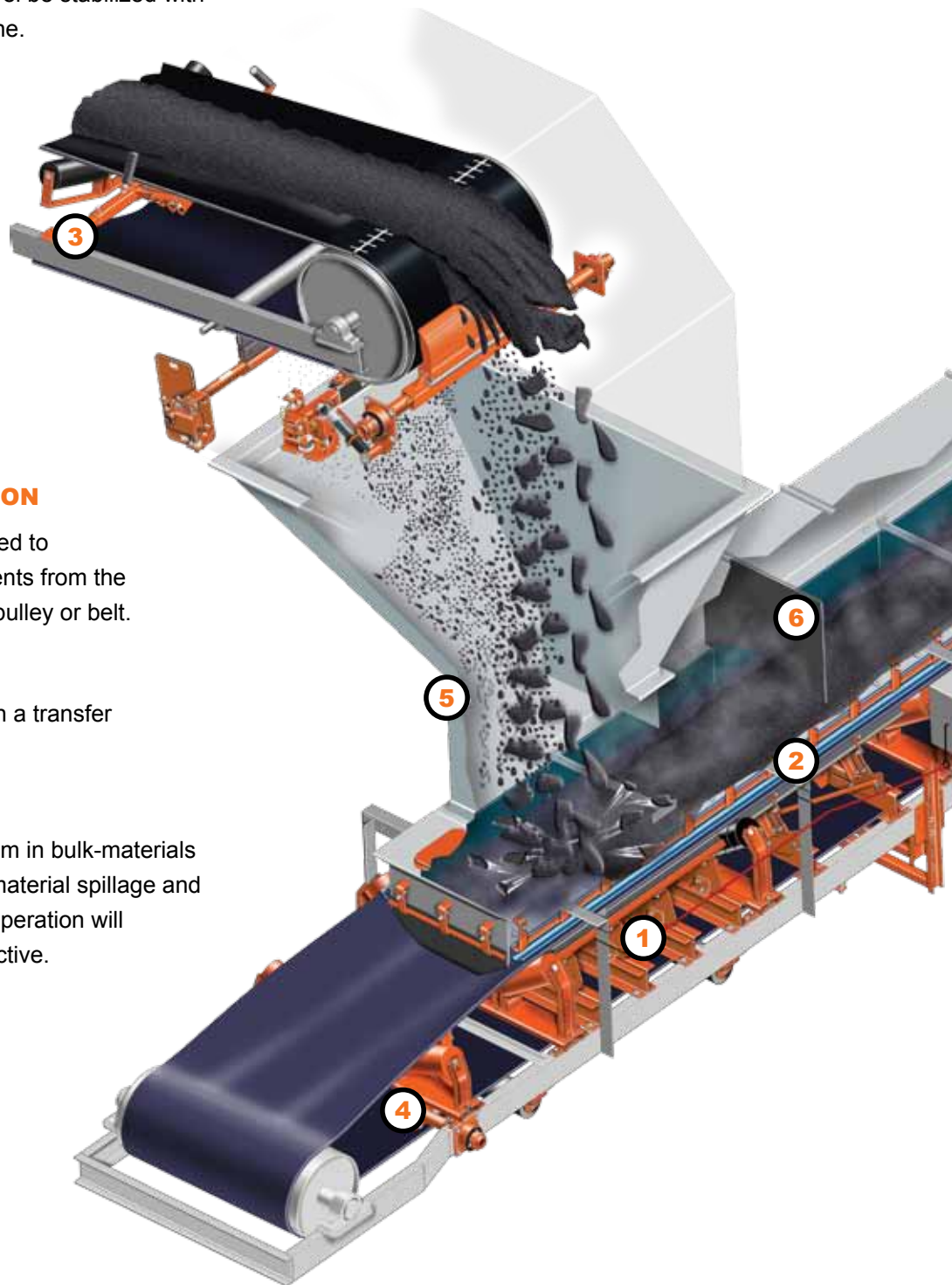



# BELT SUPPORT

## **EVO® COMBINATION CRADLE**

Installed under a belt conveyor loading zone, the EVO® Combination Cradles absorb the force of falling material to prevent damage to the belt and structure. These medium-duty impact cradles stabilize the belt line to prevent material escape.

The center-roll option reduces friction and requires less conveyor drive horsepower than bars. Roller kit available for use with multiple units.

### ***EVO® UPGRADE:***

Track-mounted to simplify installation and maintenance.



*Bar Option*



*Roller kits available for installing two units back to back.*



*Roller Option*



**MARTIN® IMPACT CRADLE**

Installed under a belt conveyor loading zone, the MARTIN® Impact Cradle absorb the force of falling material to prevent damage to the belt and structure. Wing supports adjust to match any standard trough angle. An additional five degrees of fine tuning adjustment enables the cradle to match the idler profiles of different idler manufacturers. Rugged bars are composed of a top layer of low friction UHMW and a lower layer of energy-absorbing SBR rubber.



Light Duty

**System Selection Guide:**

Determine weight of largest lump and drop height.

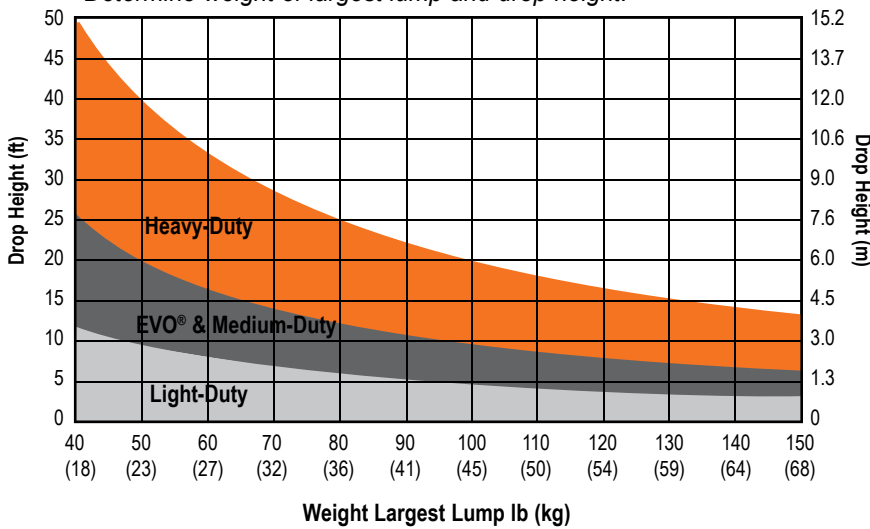

Medium Duty



Heavy Duty

**CEMA STANDARD 575-2000**

Code Rating		L	M	H
		Light-Duty	Medium-Duty	Heavy-Duty
Impact Force	(lbf.)	< 8,500	< 12,000	< 17,000
	(kN)	< 35	< 53	< 76
W x h (ref.)	lb.-ft.	< 200	< 1000	< 2000
	kg-m	< 28	< 138	< 277

**EVO® HIGH-SPEED ROLLER CRADLE**

Designed and engineered for high speed / high tonnage belts, EVO® High Speed Roller Cradles provide belt support in transfer points where belt speeds exceed the operating limits of ordinary impact bar belt support cradles.



## **EVO® SLIDER CRADLE**

Eliminates pinch points where trapped material can gouge or tear the belt and stabilizes the belt's path to improve sealing and tracking. Low-friction UHMW bars support belt edges to stabilize the belt line, eliminating belt sag and bounce. Proprietary "box" design allows each bar to be turned over to provide a second wear life.

### *EVO® UPGRADE:*

Track-mounted to simplify installation and maintenance.



## **MARTIN® SLIDER CRADLE**

Eliminates pinch points where trapped material can gouge or tear the belt and stabilizes the belt's path to improve sealing and tracking. The conveyor belt glides over its UHMW bars without heat buildup. Its unique "box bars" provide dual-wear surfaces for double wear life.

Center rollers are recommended for applications where capacity is over 450 tph (408 MT/h). Order Support Roller Kit P/N 36725.



## **MARTIN® IDLER CONVERSION KIT**

Simple retrofit links two or more troughing idler frames, replacing the wing rollers with Martin® Slider Bars. Utilizes existing idler frames and center rollers and conforms with idlers from a wide range of manufacturers.





## EVO® RETURN ROLLER

Sliding track-mount design reduces risk of injury and allows replacement to be done quickly and easily from a single side of the belt. Three-piece hanger frame accommodates belt widths 24 to 72 inches (500 to 2000 mm). Universal bracket fits most idlers and belt widths.



## MARTIN® TRAC-MOUNT™ IDLERS

Idlers slide in and out of position without the need to raise the belt or move adjacent idlers to allow simple service. Clamp mounted to allow precision installation requiring only 8 inches (203 mm) of spacing. Mild steel or rubber rollers for CEMA Class B, C, D, or E.

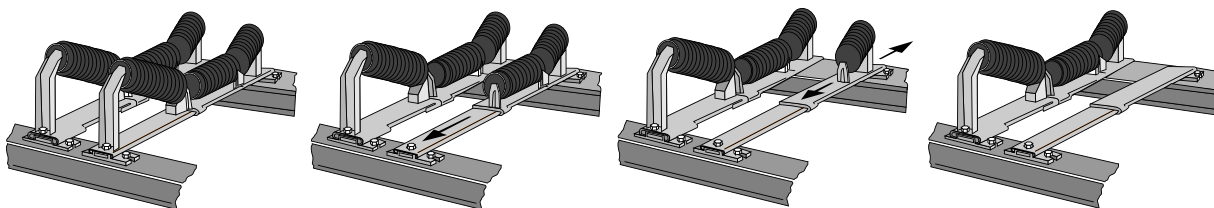
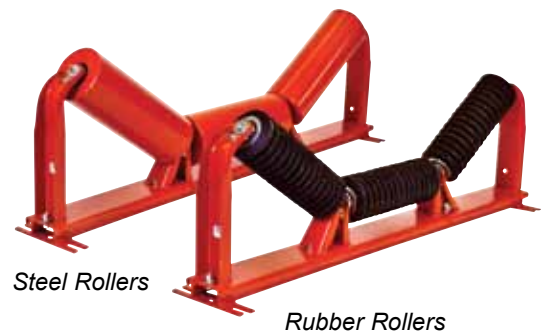

*Idler Removal: Simply remove one bolt and sliding roller frames will allow servicing without raising the belt or removing adjacent idlers.*



# SEALING SYSTEMS

## **EVO® EXTERNAL WEAR LINER**

External wear liner is installed on the outside of the chute wall, simplifying wear liner inspection and replacement—both without confined-space entry. Improves liner and skirtboard sealing system performance without adding additional conveyor construction cost. The chute wall can be trimmed to avoid material buildup.



## **MARTIN® WEAR LINER**

Installed inside conveyor transfer point skirtboards, Martin® Wear Liner creates a dam to shield the sealing system from the weight of the material load, prolonging the life of the seal.

Straight wear liner is recommended in transfer point where impact or “bounce” of the material can lead to the entrapment of lumps between deflector liners and the chute wall.

For ease of installation, Martin® Wear Liner is available with pre-drilled and countersunk mounting holes.



**MARTIN® APRONSEAL™ SKIRTING**

Provides dual-seal efficiency with a single, one-piece sealing strip for any troughing angle to prevent the escape of fines and dust.

ApronSeal™ Double Skirting uses a patented design that features a reversible elastomer strip to provide a second wear life.

Optional quick-release clamps are available.



*Standard-Duty Single Skirting (quick release clamps)*



*Double Skirting*



*Heavy-Duty Single Skirting (quick release clamps)*

**MARTIN® SELF ADJUSTING SKIRTING**

Self-adjusting skirting system rides the belt to create an effective seal automatically. Requires only six inches (152 mm) of clearance and only 1.5 inches (38 mm) free belt area for sealing. L System has an inward extension under the skirtboard to increase the range of tolerance for belt mistracking.



**Sealing Systems Application Selection Guide**

		Belt Trough Angle													
		0				20				35				45	
Free Belt Area in. (mm)	4.00 (102)	Self-Adjusting Skirting				Standard ApronSeal™				Heavy Duty ApronSeal™					
	3.75 (95)	Self-Adjusting Skirting				Standard ApronSeal™				Heavy Duty ApronSeal™					
	3.50 (89)	Self-Adjusting Skirting				Standard ApronSeal™				Heavy Duty ApronSeal™					
	3.25 (83)	Self-Adjusting Skirting				Standard ApronSeal™				Heavy Duty ApronSeal™					
	3.00 (76)	Self-Adjusting Skirting				Standard ApronSeal™				Heavy Duty ApronSeal™					
	2.50 (63)	Self-Adjusting Skirting				Standard ApronSeal™				Heavy Duty ApronSeal™					
	2.00 (51)	Self-Adjusting Skirting				Standard ApronSeal™				Heavy Duty ApronSeal™					



# BELT TRACKING

## MARTIN® TRACKER™

Provides immediate, powerful and continuous steering to correct a belt's path, preventing spillage, equipment damage and repairs. Systems for offset idlers are available. Three duty ratings available to meet material handling needs.



*upper unit*

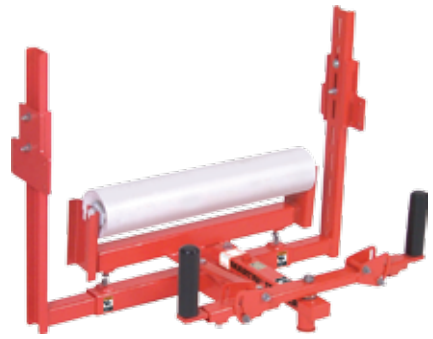

*lower unit*

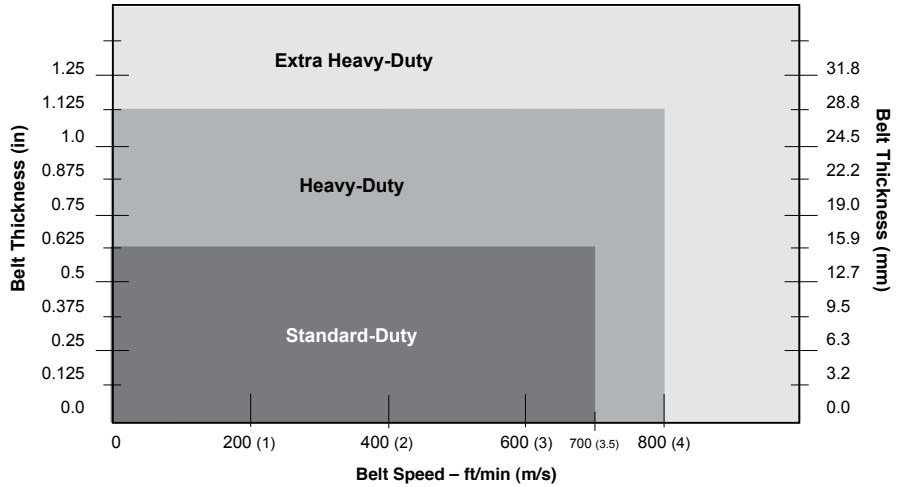

## HOW IT WORKS:

The MARTIN® Tracker has four main sections: steering roll, torque arm, parallel stay, and guide rolls. As the belt contacts the guide rolls, the torque arm pivots the steering roll, causing the belt to track to the center of the conveyor structure.

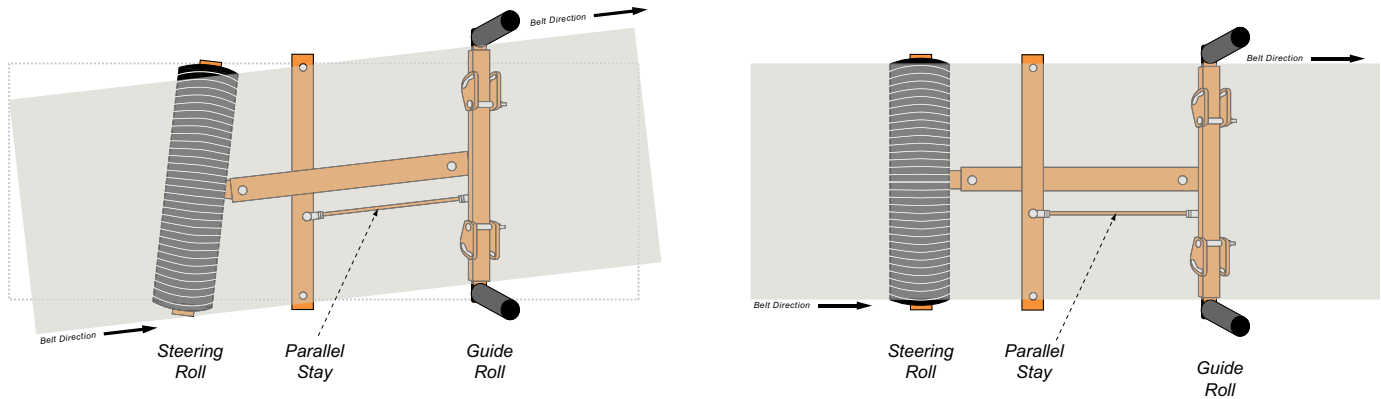

## MARTIN® REVERSING TRACKER™

Reversing Tracker™ features sensing rollers and lever arms on both sides of the unit. Employs a stainless steel paddle wheel to sense the direction of belt travel and to activate the sensing rollers on the proper end of the unit.



## MARTIN® IDLER ALIGNER

Provides a safe and effective method to manually fine tune self-adjusting idlers. Eliminates the need to tie off idlers to surrounding structure and allows workers to safely and conveniently make manual adjustments from outside of the stringer. Features a hole for padlock placement to restrict access. Installation is a one-person job, requiring no measuring, cutting or heavy lifting.





# TAIL PULLEY PROTECTION

## **MARTIN® VPLOW XHD**

Rugged, modular design with urethane side blades for longer wear and lower friction. Designed for 42 to 96 in. (1,000 to 2,400 mm) belt widths. Three-piece frame construction simply bolts together for ease of assembly. Includes reversible mounts so the frame can be cut and installed between the stringers.



## **MARTIN® VPLOW HD**

Economical solution for tail pulley protection in light- to moderate-duty applications. Effectively removes material before the conveyor enters the tail pulley, with a simple yet secure mounting that protects both plow and pulley.



### **MARTIN® TORSION VPLOW**

Mounted with self-adjusting torsion arm suspension, the Torsion VPLOW maintains consistent pressure in front of the tail pulley. It rises and falls with fluctuations in belt tension and travel, for effective cleaning in all stages of blade wear, with easy to replace, bolt on rubber or urethane blades.



### **MARTIN® DIAGONAL PLOW**

Prevents stray material from damaging the tail pulley, lagging or belting on reversing belts. Hung from brackets on both sides of the conveyor, the Diagonal Plow is engineered to float on the belt surface with pressure for cleaning, but without adding to belt tension or conveyor-drive power requirements.



### **MARTIN® DURT DOZER™ PLOW**

Installs on single-direction belts on the conveyor's return side, just before the belt enters the tail pulley. Sits across the belt at a 45° angle, using its curved blade to remove material from the inside surface of a belt moving at speeds up to 700 fpm (3.5m/sec).





# CHUTE STRUCTURE

## **EVO® STRINGER SYSTEM**

Stringers and cross members feature a unique “half-hex” design with components angled to resist material accumulation. This proprietary design is as strong as, and price-competitive with, traditional conveyor “C-Channel” structure. Stringers are predrilled for precision component positioning.



## **EVO® MODULAR CHUTE WALL**

Pre-engineered, pre-fabricated components make it easy to design and install transfer point skirt-boards and stilling zones to manage air flow and control dust. Compatible with EVO® External Wear Liner and Martin® Belt Sealing.





## EVO® SKIRTBOARD COVER

Keeps climatic conditions outside and airborne dust inside. Installs simply and reduces cleanup expenses and environmental problems by 'shedding' debris and material, to a safe area away from moving parts. Easy removal allows inspection of material and belt movement.



## TYPICAL SYSTEM COMPONENTS STILLING ZONE TRANSFER

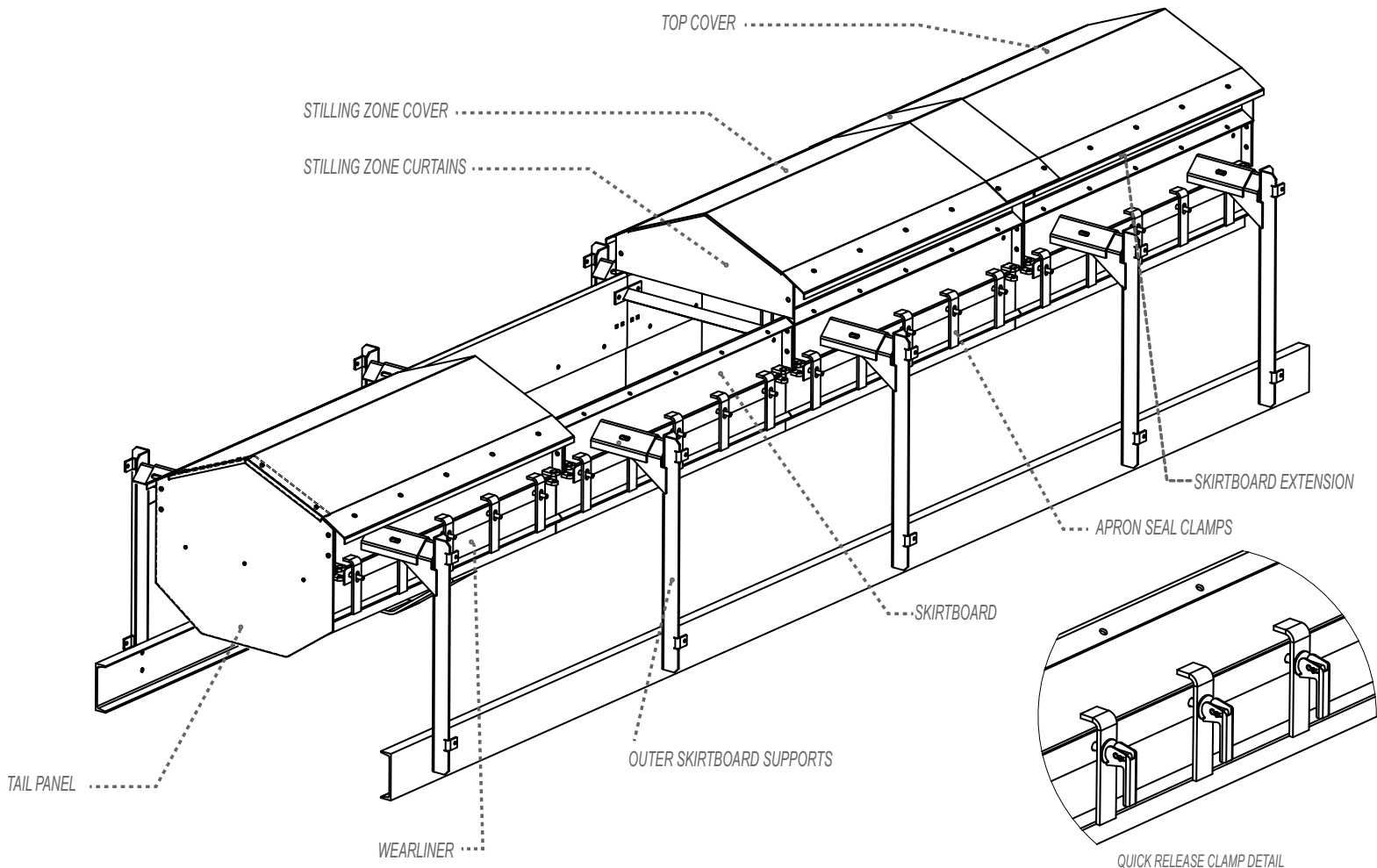

Contact your Martin Engineering representative to discuss the best solution to meet your specific needs.

# DUST MANAGEMENT

## MARTIN® DUST FIGHTER™

Martin® Dust Fighter™ products solve the problem of airborne dust by keeping fine particles in the load or by returning them to the main material body. Dust Fighter™ products include systems and components for air filtration and dust suppression.

### PASSIVE DUST CONTROL

Prevents the escape of airborne dust through minimization, containment and/or filtration.



### DUST SUPPRESSION

Minimizes the escape of airborne dust by adding moisture to the material and/or the air.



### AIR FILTRATION

Removes solid particles from the air by moving dust-laden air through a filter.



Martin Engineering can take “single source” responsibility for your dust control systems. From system design, hardware manufacturing, system installation, operator training, consumable chemical supply and system maintenance, Martin Engineering provides the “Total Solution” to fight dust.

For more information regarding our Dust Fighter™ products, please contact a Martin Engineering representative or visit [www.martin-eng.com/products/dust-management-solutions](http://www.martin-eng.com/products/dust-management-solutions).



# ACCESSORIES

To improve transfer point performance, Martin Engineering offers a number of specialized components.



## **MARTIN® CARRYBACK CAPTURE SYSTEM**

Martin® Carryback Capture System scavenger conveyor technology improves belt cleaning in tough conditions. Carryback falls into the collecting trough where a hydraulic cylinder pushes a steel blade across a steel collecting deck, moving captured material back to the point where it discharges onto the main conveyor.

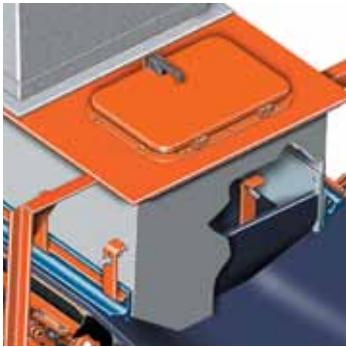

## **MARTIN® TAIL SEALING BOX**

Forms an effective seal at back of transfer point loading zone to prevent material rollback off the conveyor. Keeps material on the belt and off the floor, protecting critical moving parts and components. Back seal clamps are mounted on the outside for ease of service, but the sealing strip lies on the inside for effective sealing.



## **MARTIN® VIBRATING DRIBBLE CHUTE**

Vibrator with a unique isolation mount and low-friction chute liner prevents buildup in chutes. Rubber-lined bracket transfers vibrations to the liner without causing metal fatigue in the chute.

# SAFETY FIRST

Conveyors are one of the best productivity-enhancing tools available, but conveyor injuries cost employers millions of dollars annually. The vast majority of these injuries are preventable with the right training, preparation and safety precautions. Martin Engineering has specifically developed a wide variety of safety products and accessories designed to protect workers from hazards and risks.



## **MARTIN® RETURN ROLLER GUARDS & BASKETS**

Guards feature quick release pins which allow access to the grease fittings of the return rollers without removing the guard. Entire bottom panel can drop out to allow easy cleaning. Allows fines to fall through, but prohibits access to moving parts.

Baskets provide an economical way to improve safety and meet the growing demands of government regulations. Solid steel construction covers all major return roller manufacturers.

Guards and baskets are both all steel construction.



## **MARTIN® CONVEYOR GUARDS**

Modular approach to conveyor guarding using standardized panels that are easy to use and safety compliant. Provides an economical way to improve safety awareness and reduce worker injuries.

Easy-to-use integrated handles fold out if desired, or stay flat in areas with limited space. Wedge clamps allow panels to be removed and reinstalled quickly, with no tools.



*Steel door*

## **MARTIN® INSPECTION DOORS**

Martin® Inspection Doors feature a low profile that minimizes dust accumulation on the door and frame while providing a dust-tight seal. They provide safe and secure entry to critical maintenance areas. Available in many standard sizes in addition to custom options.



# MARTINPLUS® SERVICES

**More Control. More Efficiency. More Support.**



## **KEEP YOUR STAFF FOCUSED ON YOUR CRITICAL TASKS.**

- Experienced technicians provide faster, more error-free installations.
- Packaged service options keep budgeting flat and controlled.
- Or time and material options let you control service spending.
- Proactive service extends component life and minimizes breakdowns.



## **SERVICE BENEFITS: TRANSFER POINT SYSTEMS**

- Regular adjustment keeps material and dust under control
- Reduce risk of damage to belt and structure
- Identify minor issues before they become major problems
- Avoid unexpected failures and downtime

## BELT SUPPORT

### EVO® Combination Cradle

Tech Data Sheet	L3920
Cradle/Bars P/N	UCGGB
Cradle/Roller P/N	UCGBR
Flat Cradle P/N	31880
Picking Cradle P/N	37057
Roller Cradle Roller Kit P/N	UC-001670
Bar Material	Rubber/Urethane
Replacement Bar (Urethane/UHMW)	UC-001630
Duty Rating	Medium

### Martin® Impact Cradle HD

Tech Data Sheet	L3631
P/N	37357
Replacement Bar (Rubber/UHMW)	36570
Standard Bar Length	24 in
Top Cover Material	UHMW

### Martin® Impact Cradle LD & MD

Tech Data Sheet	L3630
Medium Duty - 4ft bars P/N	36318
Medium Duty - 5ft bars P/N	36516
Light Duty P/N	36010
Replacement Bar (Urethane/UHMW)	39102-4
Standard Bar Length	48 in.
Top Cover Material	UHMW

### Martin® Trac-Mount Idlers

Tech Data Sheet	L5385
P/N	TMIXXP
Roller Options	Steel, Impact, Combination
Diameter Range	4 to 7 inches
CEMA Classes	A through E

### EVO® Return Roller

Tech Data Sheet	L3824
P/N	UCRR

### EVO® Slider Cradle

Tech Data Sheet	L5389
P/N	UCGS
Bar Material	UHMW Polyethylene

### Martin® Slider Cradle

Tech Data Sheet	L3398-03
P/N	36700
Replacement bars P/N	31275
Standard Bar Length	48 in.
Bar Material	UHMW Polyethylene

### Martin® Idler Conversion Kit

Tech Data Sheet	L3614
P/N	37135
Bar Material	UHMW Polyethylene

### EVO® High-Speed Roller Cradle

Tech Data Sheet	L3969
P/N	HSRC

## BELT SEALING

### EVO® External Wear Liner

Tech Data Sheet	L5387
P/N	UC-003010

### MARTIN® ApronSeal™ Skirting

Tech Data Sheet	L3783
Sealing System Selection Guide	L3636
Single Skirting P/N	100724
Single Skirting HD P/N	10723
Double Skirting P/N	100873
Double Skirting HD P/N	100861
Material Durometer	60 or 70 (standard)
Continuous lengths	300 feet
Trough Range	0° to 45°
Clamp Options	standard, low-profile, heavy-duty, quick release

### MARTIN® Self Adjusting Skirting HD

Tech Data Sheet	L3617-10
P/N	37911
Replacement Rubber P/N	37911-R
Continuous Lengths	100 feet
Min. belt edge requirement	1.25 inches



## BELT ALIGNMENT

### MARTIN® Tracker™

Tech Data Sheet	L3298-11
Standard Duty P/N	TKR-(24-54)XS
Heavy Duty P/N	TKR-(36-72)XH
Extra Heavy Duty P/N	37249

### MARTIN® Tracker™ Reversing

Tech Data Sheet	L3447
Upper P/N	34695
Lower P/N	34694

### MARTIN® Idler Aligner

P/N	38654
-----	-------

## TAIL PULLEY PROTECTION

### MARTIN® VPlow XHD

Tech Data Sheet	L3772
P/N	PLWVH
Max. Belt Speed	1000 fpm
Blade Material	Urethane

### MARTIN® VPlow HD

Tech Data Sheet	L3298-12
P/N	31106
Replacement Blade P/N	31134
Max. Belt Speed:	900 fpm
Blade Material:	Rubber or Urethane

### MARTIN® Torsion VPlow

Tech Data Sheet	L3298-12
P/N	28488
Rubber Blade P/N	28496
Urethane Blade P/N	28812
Max. Belt Speed:	900 fpm
Blade Material:	Rubber or Urethane

### MARTIN® Diagonal Plow

Tech Data Sheet	L3298-12
P/N	22662
Rubber Blade P/N	24112
Urethane Blade P/N	25403
Max. Belt Speed:	900 fpm
Blade Material:	Rubber or Urethane

### MARTIN® Durt Dozer™ Plow

Tech Data Sheet	L3298-12
P/N	33600
Replacement Blade P/N	33610
Max. Belt Speed:	700 fpm
Blade Material:	Rubber

## CHUTE STRUCTURE

### EVO® Stringer System

Tech Data Sheet	L5388
Contact a representative for part number	

### EVO® Modular Chute Wall

Tech Data Sheet	L5387
P/N	UC-003000

### EVO® Skirtboard Cover

Tech Data Sheet	L5387
P/N	UC-00307

All components included for complete transfer point. Contact Martin for more details.

## ACCESSORIES

### MARTIN® Carryback Capture System

Tech Data Sheet	L3806
P/N	CCS

### MARTIN® Tail Sealing Box

Tech Data Sheet	L3298-09
P/N	33268

### MARTIN® Vibrating Dribble Chute

Tech Data Sheet	L3370-14
Vibrating dribble chute P/N	31546
Dribble Sheet liner P/N	31494
Overload protection P/N	31546-OL

## SAFETY FIRST

### Martin® Conveyor Guards

Tech Data Sheet	L3804
P/N	UCBG

### Martin® Inspection Doors

Tech Data Sheet	L3432
Rubber door P/N	CYAR
Steel door P/N	CYA
Round steel door P/N	CYARD
Extended-height steel door P/N	CYAE



#### GLOBAL LOCATIONS



UNITED STATES



AUSTRALIA



BRAZIL



CHINA



FRANCE



GERMANY



INDIA



INDONESIA



ITALY



MEXICO



PERU



SPAIN



SOUTH AFRICA



TURKEY



UNITED KINGDOM

Authorized representatives in over 32 additional countries

#### MARTIN ENGINEERING USA

One Martin Place

Neponset, IL 61345-9766 USA

800-544-2947 or 309-852-2384

[info@martin-eng.com](mailto:info@martin-eng.com)

[www.martin-eng.com](http://www.martin-eng.com)

Part No. L3649-07/13